

Location: _____



F1100-C-T

FLOOR DRAIN WITH SPANNER WRENCH COVER FOR MEMBRANE FLOOR AREAS

Specification: MIFAB® Series F1100-C-T(*)-3 (* specify strainer diameter) lacquered cast iron floor drain with anchor flange, cast iron membrane clamp with primary and secondary weepholes for waterproofing membrane, and heavy duty, solid, gas tight, spanner wrench, vandal proof, stainless steel cover for secured access. (For non-membrane floors, use MIFAB F1100-T Series.)

Function: Used in non-membrane finished areas where irregular drain use is required. Solid, gas tight, spanner wrench, vandal proof, stainless steel cover ensures secure access. Used for all types of poured finished floors.

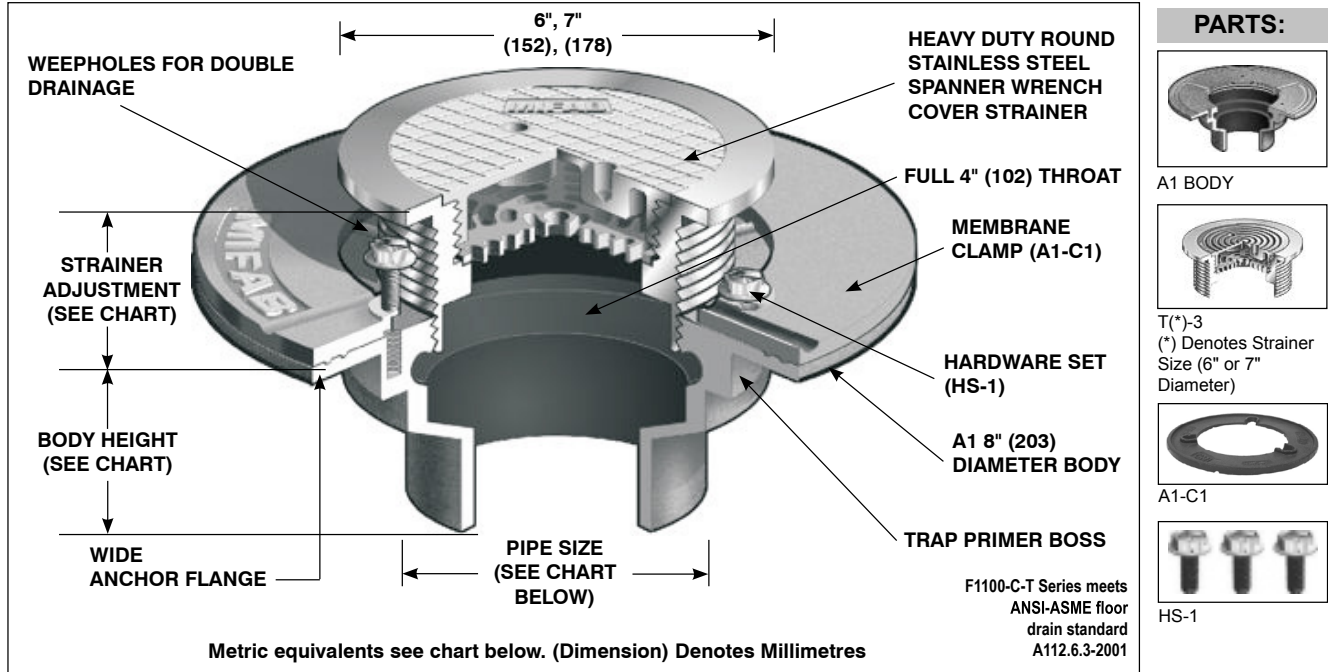

STRAINER SIZE	STRAINER ADJUSTMENT		ANSI/ASME RATING		PIPE SIZE	BODY HEIGHT				
	MIN	MAX	FREE AREA	LOAD RATING S.S. (-3)		NO HUB (STANDARD)	PUSH ON (P)	THREADED (T)	INSIDE CAULK (X)	PVC/ABS (-30)/(-31)
6" (152)	11/16" (17)	1 1/2" (38)	9 in ² (5800 ²)	5000 to 7499 LBS.	2" (51) 3" (76)	3" (76)	3 3/8" (86)	2 1/4" (57) 2 5/8" (67)	3 3/4" (95)	2 15/16" (75) 3 3/4" (95)
7" (178)	9/16" (14)	1 9/16" (40)	12 in ² (7700 ²)	5000 to 7499 LBS.	4" (102) 5" (127) 6" (152)	3" (76) 3" (76)	3 3/8" (86) --	2 5/8" (67) 2 5/8" (67)	3 3/4" (95)	3 3/4" (95) -- --

SUFFIX OPTIONAL VARIATIONS

- 3 Stainless steel strainer (vener for 9")
- 5 Sediment bucket
- 6 Security screws (T-20 Torx & pin)
- 7 1/2" trap seal primer connection
- 8 Backwater valve (2", 3", 4")
- 11 Acid resistant epoxy coated body
- 12 Galvanized top assembly
- 13 Galvanized body
- 15 Extension
- 21 Secondary flat stainless steel strainer (2", 3", 4")
- 28 Stainless steel body (Type 304)
- 30 PVC socket connection body
- 31 ABS socket connection body
- 34 Closure plug
- 40 Underdeck clamp

SUFFIX OPTIONAL VARIATIONS

- 41 Sump receiver
- 49 Chrome Plated Strainer Assembly
- 90 Threaded side outlet (2", 3", 4") (cast iron only)
- 90NH No hub side outlet (2", 3", 4") (cast iron only)
- 95 Client logo
- BA Minimum 51% material cost made in the USA
- G Oval 4" x 9" funnel
- J 6" x 3" x 1" funnel
- (Standard) No hub outlet
- MG MI-GARD Floor Drain Trap Sealer (2", 3" or 4")
- P Push on outlet
- PA Pennsylvania Steel Act compliant product
- T Threaded outlet (2", 3", 4")
- X Inside caulk outlet
- Z Extended wide elastomeric flange

CALIFORNIA PROPOSITION 65 WARNING. This product contains chemicals known to the State of California to cause cancer and birth defects or other reproductive harm.

Job Name: _____ Page No: _____
 Section No: _____ Contractor: _____
 Schedule No: _____ Purchase Order No: _____